

English Version

Hot-rolled stainless steel plates - Tolerances on dimensions and
shape (ISO 18286:2008)

Tôles en acier inoxydable laminées à chaud - Tolérances
sur les dimensions et la forme (ISO 18286:2008)

Warmgewalztes Blech aus nichtrostendem Stahl -
Grenzabmaße und Formtoleranzen (ISO 18286:2008)

This European Standard was approved by CEN on 20 May 2010.

CEN members are bound to comply with the CEN/CENELEC Internal Regulations which stipulate the conditions for giving this European Standard the status of a national standard without any alteration. Up-to-date lists and bibliographical references concerning such national standards may be obtained on application to the CEN Management Centre or to any CEN member.

This European Standard exists in three official versions (English, French, German). A version in any other language made by translation under the responsibility of a CEN member into its own language and notified to the CEN Management Centre has the same status as the official versions.

CEN members are the national standards bodies of Austria, Belgium, Bulgaria, Croatia, Cyprus, Czech Republic, Denmark, Estonia, Finland, France, Germany, Greece, Hungary, Iceland, Ireland, Italy, Latvia, Lithuania, Luxembourg, Malta, Netherlands, Norway, Poland, Portugal, Romania, Slovakia, Slovenia, Spain, Sweden, Switzerland and United Kingdom.



EUROPEAN COMMITTEE FOR STANDARDIZATION
COMITÉ EUROPÉEN DE NORMALISATION
EUROPÄISCHES KOMITEE FÜR NORMUNG

Management Centre: Avenue Marnix 17, B-1000 Brussels

Foreword

The text of ISO 18286:2008 has been prepared by Technical Committee ISO/TC 17 "Steel" of the International Organization for Standardization (ISO) and has been taken over as EN ISO 18286:2010 by Technical Committee ECISS/TC 105 "Steels for heat treatment, alloy steels, free-cutting steels and stainless steels" the secretariat of which is held by DIN.

This European Standard shall be given the status of a national standard, either by publication of an identical text or by endorsement, at the latest by December 2010, and conflicting national standards shall be withdrawn at the latest by December 2010.

Attention is drawn to the possibility that some of the elements of this document may be the subject of patent rights. CEN [and/or CENELEC] shall not be held responsible for identifying any or all such patent rights.

According to the CEN/CENELEC Internal Regulations, the national standards organizations of the following countries are bound to implement this European Standard: Austria, Belgium, Bulgaria, Croatia, Cyprus, Czech Republic, Denmark, Estonia, Finland, France, Germany, Greece, Hungary, Iceland, Ireland, Italy, Latvia, Lithuania, Luxembourg, Malta, Netherlands, Norway, Poland, Portugal, Romania, Slovakia, Slovenia, Spain, Sweden, Switzerland and the United Kingdom.

Endorsement notice

The text of ISO 18286:2008 has been approved by CEN as a EN ISO 18286:2010 without any modification.

Contents

Page

Foreword.....	iv
1 Scope	1
2 Normative references	1
3 Information to be supplied by the purchaser	1
3.1 General.....	1
3.2 Purchase order options.....	2
4 Designation	2
5 Form of supply	2
6 Tolerances on dimensions	3
6.1 Thickness	3
6.2 Width and length.....	3
7 Tolerances on shape	5
7.1 Edge camber and out-of-squareness	5
7.2 Flatness	5
8 Excess mass	6
9 Measurements.....	6
9.1 General.....	6
9.2 Thickness	6
9.3 Width	6
9.4 Length	6
9.5 Edge camber	7
9.6 Out-of-squareness.....	7
9.7 Flatness	7
10 Purchase order options.....	7
Bibliography	8

Foreword

ISO (the International Organization for Standardization) is a worldwide federation of national standards bodies (ISO member bodies). The work of preparing International Standards is normally carried out through ISO technical committees. Each member body interested in a subject for which a technical committee has been established has the right to be represented on that committee. International organizations, governmental and non-governmental, in liaison with ISO, also take part in the work. ISO collaborates closely with the International Electrotechnical Commission (IEC) on all matters of electrotechnical standardization.

International Standards are drafted in accordance with the rules given in the ISO/IEC Directives, Part 2.

The main task of technical committees is to prepare International Standards. Draft International Standards adopted by the technical committees are circulated to the member bodies for voting. Publication as an International Standard requires approval by at least 75 % of the member bodies casting a vote.

Attention is drawn to the possibility that some of the elements of this document may be the subject of patent rights. ISO shall not be held responsible for identifying any or all such patent rights.

ISO 18286 was prepared by Technical Committee ISO/TC 17, *Steel*, Subcommittee SC 4, *Heat treatable and alloy steels*.

This second edition cancels and replaces the first edition (ISO 18286:2004), of which it constitutes a minor revision.

Hot-rolled stainless steel plates — Tolerances on dimensions and shape

1 Scope

This International Standard specifies requirements for tolerances for hot-rolled stainless steel plates (quarto plates) made on a reversing mill with the following characteristics:

- a) nominal thickness, t , such that $4 \text{ mm} \leq t \leq 250 \text{ mm}$;
- b) nominal width, w , such that $w \geq 600 \text{ mm}$.

Tolerances for plate of width $w < 600 \text{ mm}$ cut or slit from wider plate should be agreed upon between manufacturer and purchaser at the time of enquiry and order.

This International Standard is not applicable to round plates, custom-made plates, checker plate or bulb plate for flooring or wide flats, nor to continuous-process plates (plate made with coiling).

This International Standard does not include round plates, custom-made plates, checker plate or bulb plate for flooring or wide flats. It does not include continuous process plates (plate made with coiling) because tolerances for these plates are defined in another International Standard (see ISO 9444).

2 Normative references

The following referenced documents are indispensable for the application of this document. For dated references, only the edition cited applies. For undated references, the latest edition of the referenced document (including any amendments) applies.

ISO/TS 15510:2003, *Stainless steels — Chemical composition*

ISO 16143-1:2004, *Stainless steels for general purposes — Part 1: Flat products*

3 Information to be supplied by the purchaser

3.1 General

The following information shall be supplied by the purchaser at the time of enquiry and order:

- a) description of the product (plate);
- b) reference to this International Standard, ISO 18286;
- c) nominal thickness, in millimetres;
- d) nominal width, in millimetres;
- e) the letters NK, if plate with mill edges is required [see 6.2.2 and Clause 10 a)];

- f) nominal length, in millimetres;
- g) width and length tolerances, Class A (in accordance with Tables 2 and 3), Class B (in accordance with Table 4) or Class C (in accordance with Table 5), see 6.2;
- h) flatness tolerance class, Class N (in accordance with Table 6) or Class S (in accordance with Table 7), see 7.2.1;
- i) requirements concerning limits for excess mass (see Clause 8).

3.2 Purchase order options

A number of options are listed in Clause 10. In the absence of any specification of these options by the purchaser at the time of enquiry and purchase order, the manufacturer is permitted to deliver in accordance with the basic requirements of this specification (see 5.2).

4 Designation

The designation of products in accordance with 3.1 shall also include the exact designation of the ordered steel grade, in accordance with the following examples:

- a) plate in accordance with this International Standard with nominal thickness of 20 mm, nominal width 2 000 mm, with trimmed edges, nominal length 4 500 mm, with width and length tolerances Class B (in accordance with Table 4), with special flatness tolerances in accordance with Table 7 (Class S), grade X2CrNi18-9 as specified in ISO 16143-1:2004

**plate ISO 18286 – 20 × 2000 × 4500 B S,
steel ISO 16143-1 – X2CrNi18-9**

- b) plate in accordance with this International Standard with nominal thickness of 4,5 mm, nominal width 1 500 mm, with mill edge (NK), with width tolerance $\begin{matrix} +100 \\ 0 \end{matrix}$ mm, nominal length 2 800 mm and length tolerance class A (in accordance with Table 3), with normal flatness tolerances in accordance with Table 6 (Class N), grade X2CrNiMo17-12-2 as specified in ISO 16143-1:2004

**plate ISO 18286 – 4,5 × 1500 NK –0/+100 × 2800 A N,
steel ISO 16143-1 – X2CrNiMo17-12-2**

5 Form of supply

5.1 Plate shall be supplied

- a) with thickness tolerances as specified in Table 1 (see 6.1.1),
- b) with trimmed edges or with mill edges (NK) (see 6.2.2),
- c) with normal (N in Table 6) or with special (S in Table 7) flatness tolerances (see 7.2).

5.2 In the absence of information or code letters, as defined in 3.1 g) and h), in the purchase order, plate shall be supplied as follows:

- a) tolerances on length and width in accordance with Class A (see Tables 2 and 3);
- b) normal tolerances for flatness, Class N (see Table 6).

6 Tolerances on dimensions

6.1 Thickness

6.1.1 Tolerances on thickness are given in Table 1.

6.1.2 Unless otherwise agreed upon in the order by the manufacturer and purchaser, the thickness of the plate in all areas, including ground areas, shall meet the minimum thickness requirements for the nominal thickness.

Table 1 — Tolerances on thickness

Dimensions in millimetres

Nominal thickness t^a	Width w			
	$w < 2\,100$	$2\,100 \leq w < 3\,000$	$3\,000 \leq w < 3\,600$	$w \geq 3\,600$
$t < 10$	+1,15	+1,30	+2,15	—
$10 \leq t < 20$	+1,40	+1,55	+2,15	+2,30
$20 \leq t < 25$	+1,55	+1,65	+2,15	+2,55
$25 \leq t < 50$	+1,80	+1,90	+2,40	+2,95
$50 \leq t < 75$	+2,55	+2,75	+2,95	+3,15
$75 \leq t < 100$	+2,75	+2,95	+3,15	+3,35
$100 \leq t < 150$	+2,95	+3,15	+3,35	+3,55
$150 \leq t < 200$	+3,35	+3,55	+3,75	+3,95
$200 \leq t \leq 250$	+3,75	+3,95	+4,15	+4,35

^a For plate of thickness ≤ 250 mm, the tolerance under the nominal thickness shall be 0,30 mm.

6.2 Width and length

6.2.1 Tolerances on width and length for plate with trimmed edges are given in Tables 2, 3, 4 and 5. At the time of enquiry and purchase order, the purchaser shall specify which width and length tolerance class is applicable to the purchased material, tolerance Class A (tolerances on width in accordance with Table 2 and tolerances on length in accordance with Table 3), tolerance Class B (tolerances on width and length according to Table 4) or tolerance Class C (tolerances on width and length in accordance with Table 5).

The choice of the trimming procedure is left to the manufacturer's discretion, unless otherwise stated in the purchase order.

Table 2 — Tolerances on width for Class A

Dimensions in millimetres

Nominal width w	Tolerances	
	Lower	Upper
$600 \leq w < 2\,000$	0	+15
$2\,000 \leq w < 3\,000$	0	+20
$w \geq 3\,000$	0	+25

Table 3 — Tolerances on length for Class A

Dimensions in millimetres

Nominal length L	Tolerances	
	Lower	Upper
$600 \leq L < 4\,000$	0	+20
$4\,000 \leq L < 6\,000$	0	+30
$6\,000 \leq L < 8\,000$	0	+40
$8\,000 \leq L < 10\,000$	0	+50
$10\,000 \leq L < 15\,000$	0	+75
$15\,000 \leq L \leq 20\,000^a$	0	+100

^a Tolerances on plates with a nominal length > 20 000 mm shall be agreed at the time of the enquiry and order [see Clause 10 b)].

Table 4 — Tolerances on width and length for Class B (i.e. flame-cut plate)

Dimensions in millimetres

Nominal thickness t	Tolerances	
	Lower	Upper
$t \leq 50$	0	+10
$50 < t \leq 75$	0	+13
$75 < t \leq 150$	0	+19

Table 5 — Tolerances on width and length for Class C (i.e. abrasive-cut plate)

Dimensions in millimetres

Nominal thickness t	Tolerances ^a
$t \leq 25$	3,2
$25 < t \leq 50$	4,8
$50 < t \leq 75$	6,4
$75 < t \leq 100^b$	7,9

^a The tolerances under nominal width and length are 3,2 mm.

^b Width and length tolerances for abrasive-cut plates over 100 mm thickness are subject to agreement between manufacturer and purchaser [see Clause 10 c)].

6.2.2 Tolerances on width for plates with mill edges (NK) shall be the subject of agreement between the manufacturer and purchaser at the time of enquiry and order.

7 Tolerances on shape

7.1 Edge camber and out-of-squareness

7.1.1 For plate specified with trimmed edges in the enquiry and in the purchase order, the edge camber shall not exceed 0,5 % of the nominal length of the plate, and the out-of-squareness shall not exceed 1 % of the nominal width of the plate.

7.1.2 For plate specified with untrimmed edges in the enquiry and in the purchase order, the edge camber and out-of-squareness of the plate shall be limited so that it is possible to inscribe a rectangle of the nominal length and width of the ordered plate within the delivered size.

7.2 Flatness

7.2.1 Tolerances on flatness are given in Table 6 for normal tolerances (Class N) and in Table 7 for special tolerances (Class S). At the time of enquiry and purchase order, the purchaser shall specify which of the flatness tolerance tables is applicable to the purchased material. In the absence of such specification by the purchaser, the manufacturer is permitted to deliver product conforming to any of the flatness tolerance tables.

7.2.2 The steel types in accordance with Tables 6 and 7 are defined as follows:

- Steel type A: All stainless steel grades except those covered by the description for steel type B given below;
- Steel type B: Stainless steel grades with Ni > 20 % or Mo > 2 % or N > 0,11 % mass fraction.

Table 6 — Normal tolerances for flatness, Class N

Dimensions in millimetres

Nominal thickness t	Steel type A ^a		Steel type B ^a	
	Measuring length ^b			
	1 000 ^c	2 000	1 000 ^c	2 000
$4 \leq t < 5$	9	14	12	17
$5 \leq t < 8$	8	12	11	15
$8 \leq t < 15$	7	10	10	14
$15 \leq t < 25$	7	10	10	13
$25 \leq t < 40$	6	9	9	12
$40 \leq t \leq 250$	5	8	8	11

^a See 7.2.2.

^b Unless otherwise specified [see Clause 10 d)], the measuring length is left to the discretion of the manufacturer.

^c If the distance between the points of contact of the straightedge and the plate is < 1 000 mm, the permissible deviation from flatness shall comply with the following: for steel type A maximum 1 % or for steel type B maximum 1,5 % of the distance between the points of contact on the plate between 300 mm to 1 000 mm, but not exceeding the values given in Table 6.

Table 7 — Special tolerances for flatness, Class S

Dimensions in millimetres

Nominal thickness t	Steel type A ^{a, b}				Steel type B ^a	
	$w < 2\,750$		$w \geq 2\,750$			
	Measuring length ^c					
	1 000	2 000	1 000	2 000	1 000	2 000
$3 \leq t < 8$	4	8	5	10	Shall be agreed upon at the time of enquiry and order	
$8 \leq t \leq 250$	3	6	3	6		

^a See 7.2.2.

^b If the distance between the points of contact of the straightedge and the plate is < 1 000 mm, the permissible deviation from flatness shall comply with the following: maximum 0,5 % of the distance between the points of contact, but not exceeding the values in Table 7 and not < 2 mm.

^c Unless otherwise specified [see Clause 10 d)], the measuring length is left to the discretion of the manufacturer.

8 Excess mass

8.1 Excess mass is the difference between the actual delivered mass and the theoretical mass, expressed as a percentage of the theoretical mass of the specified plate. The theoretical mass shall be determined using the density appropriate to the stainless steel grade as given in ISO/TS 15510:2003.

8.2 The limits for excess mass shall be agreed upon at the time of enquiry and order.

9 Measurements

9.1 General

Measurements shall be carried out at ambient temperature.

9.2 Thickness

9.2.1 Thickness of plates with trimmed edges shall be measured at any point more than 10 mm but less than 75 mm from a longitudinal edge of the plate.

9.2.2 For plates ordered with untrimmed edges, the measuring points shall be agreed upon at the time of enquiry and order.

9.3 Width

Width shall be measured in the plane of the plate on a line perpendicular to the major axis of the plate.

9.4 Length

The length of the plate is the length of the largest rectangle contained within the plate.

9.5 Edge camber

The edge camber, q , is the maximum deviation between one longitudinal edge and the straight line joining the two ends of this edge. It is measured on the concave edges of the plate (see Figure 1).

9.6 Out-of-squareness

The out-of-square value, u , is the orthogonal projection of one transverse edge on one longitudinal edge (see Figure 1).

9.7 Flatness

See Table 6 for normal tolerances for flatness, and Table 7 for special tolerances. To assess the flatness, the steel plate shall be placed on a flat surface. Deviation from flatness shall be determined by measuring the deviation in distance between the plate and a straightedge of 1 000 mm or 2 000 mm length which may be placed in any direction. Only the part situated between two points of contact between the straightedge and the plate shall be taken into consideration. Deviations shall be measured at a point at least 25 mm from the longitudinal edges and at a distance at least 200 mm or 100 mm from the plate ends, depending on whether normal (Table 6) or special (Table 7) tolerances are specified (see Figure 1).

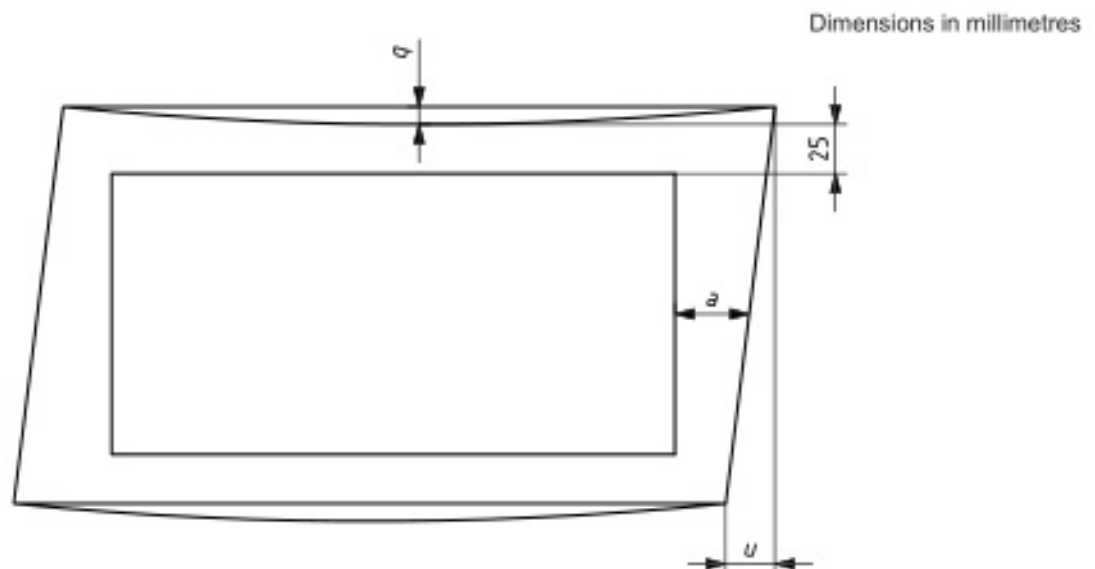

Key

- a distance from the plate end (= 200 mm for normal and = 100 mm for special flatness tolerances)
- q edge camber
- u out-of-squareness

Figure 1 — Measuring of edge camber, out-of-squareness and flatness

10 Purchase order options

The following options may be specified when placing enquiry and purchase orders:

- a) whether mill edges are required [see 3.1 e) and 6.2.2];
- b) what tolerances on length are required for plates of nominal length $L > 20\,000$ mm (see Table 3);
- c) what tolerances for width and length are required for abrasive-cut plates of thickness $t > 100$ mm (see Table 5);
- d) what measuring length shall be applied for flatness measurement (see Tables 6 and 7).

Bibliography

- [1] ISO 9444, *Continuously hot-rolled stainless steel strip, plate/sheet and cut lengths — Tolerances on dimensions and form*

